



INSTALLATION AND OPERATING
INSTRUCTIONS

DYNATHERM FP MODELS 18, 24, 36, 48

Manufactured By

DYNATHERM

a Division of PRODEX, INC.

43 E Cherry Road

Quakertown, PA 18951

(215) 536-4078 Fax: (215) 536-8960

www.dynathermboiler.com

TABLE OF CONTENTS

	<u>PAGE</u>
GENERAL DESCRIPTION	2
BILL OF MATERIALS	3
FP BOILER LAYOUT	4
BOILER DESCRIPTION & OPERATION	5
BURNER DESCRIPTION	6
CONTROLS DESCRIPTION	6
BOILER INSTALLATION	7
LEVELING	7
JACKET INSTALLATION	7
CHIMNEY	7
CHIMNEY AND BREECHING REQUIREMENTS	8
GENERAL OPERATION	8
SAFETY PRECAUTION	9
INITIAL BURNER SET UP & START UP PROCEDURE	9
BOILER MAINTENANCE	9
INSTRUCTIONS FOR DISASSEMBLY AND REASSEMBLY OF BOILER	10
BOILER CLEANING PROCEDURE	11
FP SERIES SPECIFICATIONS	13
DYNATHERM RATINGS & APPROVALS	14
BELOW GROUND DIRECT VENTING APPLICATION SCHEMATIC	15
NOTES	16

INSTALLATION and OPERATING INSTRUCTIONS

DYNATHERM BOILERS Models FP 18, 24, 36, 42, & 48

GENERAL DESCRIPTION

The **DYNATHERM** Model FP Series is a high quality fabricated steel boiler of the Scotch Marine Design, long recognized as the most efficient boiler design in this size category. It will provide years of economical heat and hot water when properly installed and cared for. It is, therefore, important that these instructions be followed carefully.

The boiler comes with a burner package and jacket. The burner package includes the following items:

- | | |
|---------------------------|------------------|
| 1. BURNER | 6. RELIEF VALVE |
| 2. AIR TUBE/FLANGE/GASKET | 7. AQUASTAT |
| 3. NOZZLE | 8. SMOKE CAP |
| 4. HARNESS ASSEMBLY | 9. HARDWARE |
| 5. T & P GAUGE | 10. WARRANTY PKG |

Boilers are shipped unskidded. Burner package and jacket are shipped in separate cartons.

Upon receipt of this material, all cartons should be inspected for obvious damages and this damage should be noted on the carrier's waybill. Keep all damaged cartons and request the service of the carrier's inspector. Claims should be made within (5) days after receipt.

All materials are shipped f.o.b. factory. It is the responsibility of the consignee to file any claims with the delivering carrier for material received in a damaged condition.

DOE RATED



IBR RATED



ASME CONSTRUCTED (Available)

BILL OF MATERIALS

DYNATHERM FP MODEL

<u>#</u>	<u>Item</u>	<u>Code #</u>
1	Boiler Shell	-
2	Front Tube Sheet	-
2a	Rear Tube Sheet	-
3	Fire Tube	
	Model 18	306.006
	Model 24	306.000
	Model 36	306.001
	Model 42	306.007
	Model 48	306.002
4	Combustion Tube	-
5	Liner, Combustion Tube	503.009
9	Tankless Coil	
	Model 18	500.009
	Model 24	500.000
	Model 36	500.002
	Model 42	500.012
	Model 48	500.003
10	End Head, 70L	920.003
11	Refractory Insert, End Head	921.000
12	Frame, 3" Peephole	100.315
13	Glass, 3" Peephole	102.316
14	Gasket, 3" Peephole	100.317
15	Slide/Lever Assembly, 3" Peephole	202.102
35	Front Head 69U - 4" Opening	200.101
38	Triple Aquastat	403.065
40	Third Pass Chamber	-
41	Flue Connection	-
42	Scroll	210.000
43	Temp & Pressure Gauge	502.000
44	Fiberglass Insulation	-
45	Gasket, Rope 3/8"	100.303
47	Gasket, Rope 1/2"	100.301
48	Insulator, Air Tube	960.001
49	2" Riser Coupling	-
50	1" Pipe Coupling	-
52	Inspection Plate	211.000
52a	Gasket, Inspection Plate	100.003
53	Coil Gasket	100.001
55	1/2" Coupling	-
59	2" Coupling Tee Return	-
60	Retention Head Oil Burner	-
72	Burner Adaptor Gasket	100.202

FP BOILER LAYOUT

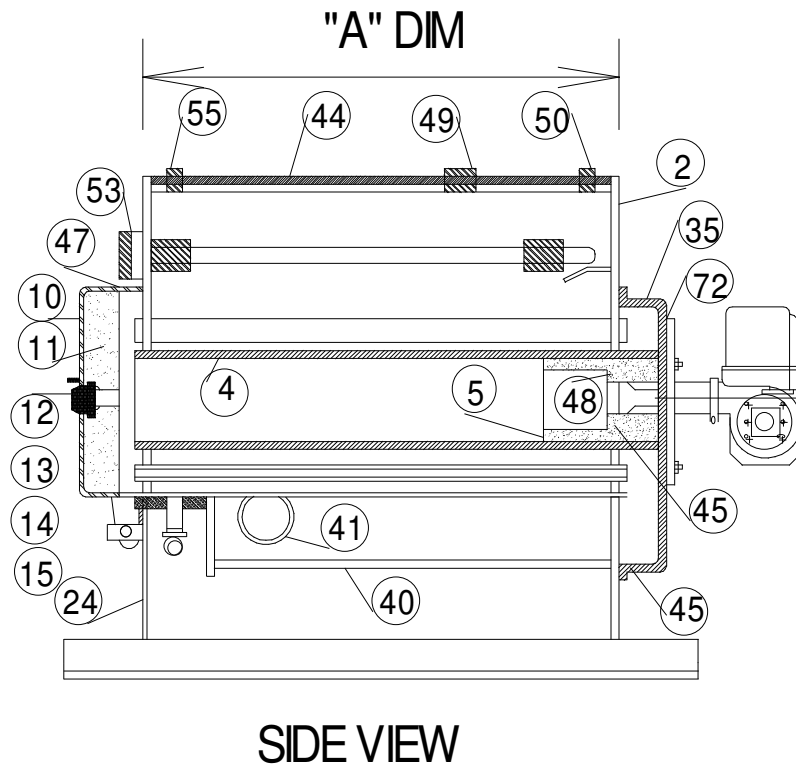
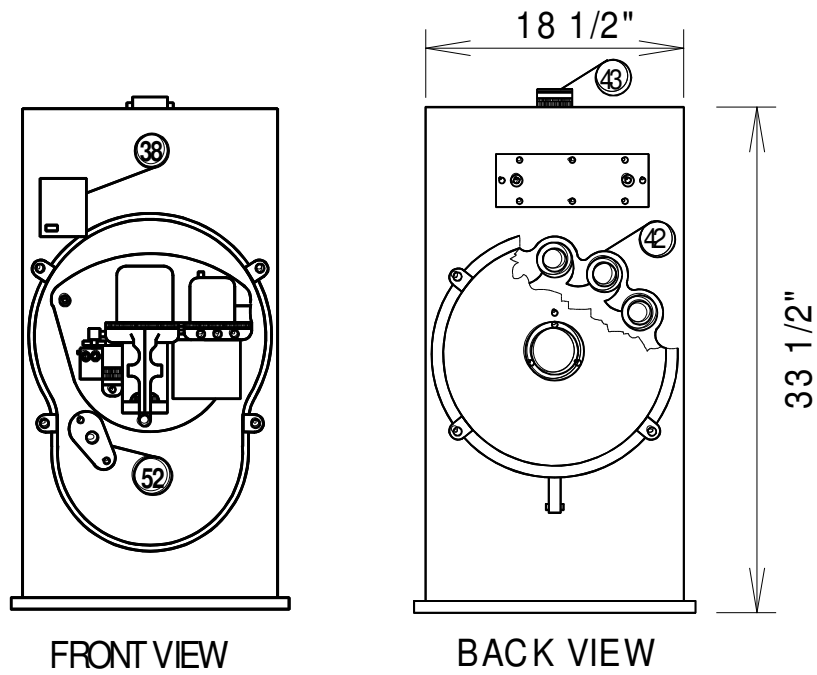

BOILER DESCRIPTION AND OPERATION

Hot gasses of combustion, produced by the *retention head oil burner* at *the front head*, are driven through the *combustion tube* to the *end head*, which houses the *scroll*. Entering the end head, the gasses are separated into 13 curls of the scroll, and spun, at greatly increased velocity, into the 13 fire tubes that surround the combustion tube in a radial orientation.

NOTE: The swirling of the gasses in the fire tubes produces a dual effect. First, the gasses, describing a curling pattern of progress through the tubes, are retained in the tubes 2 1/2 to 3 times longer, affording the gasses a longer period of time to transfer their heat, BTUs, through the tube and into the surrounding water. Second, the action caused by these gasses, in their curling motion, "bumping" along the inner walls of the tubes, creates what is called a "scrubbing" effect which greatly enhances the efficiency of the heat transfer from gasses into the fire tube walls.

The gasses exit the fire tubes, still driven by the power of the burner fan. They then enter the outer passages of the *front head*, and are directed downward into *the third pass chamber*, where they transmit heat through the bottom of the *boiler shell* before entering the *flue* from that bottom location. All the water being heated is contained in the boiler shell, through which the *combustion tube* and *fire tubes* pass, and to which the *third pass chamber* is attached. The *tube sheets*, welded to the ends of the boiler shell, form the closure for the water chamber.

The three pass Scotch Marine design utilizes all BTU input through direct contact of gasses to the heating surfaces, allowing the maximum available heat to transfer to the boiler water. The gasses are, at all times during their passage through the boiler, in intimate contact with "water backed" surfaces.

The exceptional efficiency which results is evidenced by the unusually low stack temperature. **DYNATHERM** efficiency ratings to 90.9%. Stack temperatures range from 240 to 370° F.

IMPORTANT - PLEASE NOTE:

DYNATHERM is a positive pressure boiler and seals must be air tight. These seals are the rope gaskets (items 45 and 47), and the inspection plate gasket (item 52a), as listed on the Bill of Materials. Leaks in these seals will result in improper operation of the boiler causing smoke and poor CO₂ levels.

The *combustion tube liner* is used to provide protection for the combustion tube, and assists in maintaining good smokeless combustion.

The burner *air tube insulator* protects the air tube. The *combustion tube liner* and the air tube insulator must be in place against the *front head* prior to starting the burner.

Burner operation can be observed from the rear of the boiler at the *peephole port*. A *cast iron shield* can be conveniently rotated to one side in order to view the fire. The cover must be returned to cover the glass when not in use.

The *hot water coil* is made of finned copper tubing. It is positioned in the hottest boiler water just above the *tubes*. This location provides for immediate response to the domestic hot water requirement.

BURNER DESCRIPTION

Please refer to the following table for the most suitable burner:

BOILER	RIELLO F40 SERIES			CARLIN	BECKETT AFII	
	F3	F5	F10	99	100	150
FP18	X	X		X	X	
FP24		X		X	X	X
FP36		X		X		X
FP42		X	X	X		X
FP48			X			

The **Riello** F40 Series burner is supplied with a single stage pump. A complete description of the burner set-up procedure can be found in the **RIELLO** INITIAL SET-UP section of this manual.

CONTROLS DESCRIPTION

Hot water boilers are equipped with a Honeywell L8124A1114 Triple Acting Aquastat. This unit serves as the boiler water sensing unit. The high temperature, low temperature and temperature differential are set dials in the unit.

Steam boilers have different controls since the steam boiler is controlled by a pressure sensing device instead of a temperature sensor. A Honeywell Model PA404 Pressuretrol serves as the high limit function. It can be set to operate the boiler at any pressure up to 15 psi. A Honeywell L4006A Aquastat senses the low temperature limit of the boiler.

Since a steam boiler is not full of water while operating, a Low Water Cutoff is used to insure the tubes are always immersed in water. If the water level gets too low, the low water cutoff turns the burner off.

BOILER INSTALLATION

GENERAL LOCATION

The boiler should be located so that the flue pipe from the boiler to the chimney is as short as possible, not exceeding three 90° elbows in the breeching. Some working room should be provided on the side of the boiler for piping the water return. The return and the flue can be piped from either side of the **DYNATHERM**. A stainless steel Flue Cap is supplied for the side not used. The unused return connection can be used as a boiler drain.

18" minimum clearance should be provided in the front (burner end) for servicing. Clearance must also be provided at the back of the boiler in order to insure the domestic hot water coil can be removed if required. This clearance is approximately the length of the boiler itself since the coil is almost as long as the boiler.

A suitable enclosure, usually a basement, is a desirable location for the boiler.

LEVELING

Most basement floors are pitched toward the drain. The **DYNATHERM** should be shimmed level. If the floor is damp, it is recommended that the boiler be supported on blocks or framing with a non-oxidizing material (brick, slate, etc.) above the floor for ease of servicing and to minimize piping and flue connection requirements.

JACKET INSTALLATION

Once the unit is located and shimmed to a level position, it is ready for piping, control, and wiring connections. **The jacket top must be installed prior to plumbing of the boiler.**

CHIMNEY

Chimney troubles often result in the heating unit being blamed unjustly for many complaints. Cracked tile and unlined chimneys lead to leakage of the products of combustion which, when combined with water vapors, mar the external sides of the chimney.

Care should be taken to be certain that chimneys are clean of flyash or carbon. **DYNATHERM**, with its low stack temperature, will cause any deposits of these materials to fall down and block the escape of the products of combustion. This, of course, will cause a malfunction of the unit and result in dirty operation, requiring a complete cleaning of the unit.

Fireplaces on the same flue section as the heating unit are sources of noise and vibration and, if possible, should be segregated. Many chimneys are placed with three-side exposure to the outside. **DYNATHERM**, with its low stack temperature, occasionally causes the water

vapors to condense. If the chimney is in bad condition, unlined or unprotected from precipitation, this condensation will flow down the inside and, in some cases, down the outside of the chimney. This can be eliminated with the installation of an H-stack cap or other stack-capping devices similar to the Wigwam cap. In extreme cases, an opening to the chimney from the basement will tend to dry out chimneys. When this is applied on a **DYNATHERM** installation, care should be taken to install a barometric damper in the chimney proper and below the entrance of the **DYNATHERM** exhaust vent. A suitable cleanout with cap should be installed in the base of the chimney below the entrance of the **DYNATHERM** exhaust vent, this pipe should be at least 6" in diameter.

CHIMNEY AND BREECHING REQUIREMENTS

The **DYNATHERM** FP boiler is bottom vented in order to take full advantage of all residual heat remaining in the boiler when the burner shuts off. The hot gasses rise and are trapped to transfer more heat to boiler water. Air flow through the **DYNATHERM** is minimized when the burner is off-cycle due to the draft resistance of the three pass design.

The **DYNATHERM** is a positive pressure boiler in which the flue gasses are actually being forced through the boiler instead of being drawn out by natural draft. This provides better heat transfer and more uniform firing independent of outside atmospheric conditions which often affect natural draft boilers.

The high thermal efficiency of the **DYNATHERM** results in a very low stack temperature.

The **DYNATHERM** should have a separate inlet to the chimney. Other types of burners such as those on a hot water heater, should not be piped into the **DYNATHERM** duct but should be vented into the chimney in a separate connection above the **DYNATHERM** breeching.

The design flue connection size is 5", and the breeching to the chimney should be 5" pipe. Since this is a forced draft system, all joints in the flue pipe must be made gas tight by sealing with thermosetting pressure sensitive tape.

GENERAL OPERATION

Oil fired hot water boilers and associated controls have evolved over the years to a point at which they are absolutely safe and will operate automatically in your home.

Proper operation depends on following the installation instructions. A qualified heating contractor or installer must be used in order to validate the warranty.

SAFETY PRECAUTION

A water make-up circuit should be used with hot water boilers. This circuit automatically adds water to the system when necessary. Great care should be used to insure that all air is out of the boiler before firing the burner. If the boiler is being fired without being full of water, the tubes can loosen and leak. This is negligent operation and is not covered under warranty. Anytime any line in the system is opened, air must be bled from the high points of the system. The boiler should be double checked for air.

INITIAL BURNER SET UP AND START UP PROCEDURE

Please refer to the Burner Installation manual provided with your burner.

Use instruments to adjust settings to realize 11 - 13 % CO₂ and a smoke reading of zero. NOTE: Variations in flue gas, smoke, CO₂ and temperature readings may be experienced when the burner cover is put in place. Therefore, the burner cover must be in place when making the final combustion instrument reading, to ensure proper test results.

IMPORTANT: An external, appropriately listed and certified oil filter must be placed in the fuel line between the fuel tank and the burner pump.

BOILER MAINTENANCE

INSPECTION

An oil fired boiler is operating properly when there is no smoke. A Zero smoke reading on the Bacharach scale is an acceptable indication. The CO₂ level should be between 11 and 13%. If either of these two conditions is not obtainable, an inspection of the equipment and the functional parameters is indicated.

Visual examination of the gasketed front head, end head, inspection plate, and burner flange will usually expose slight gas leaks out of the boiler. Small soot deposits may form on the tube sheet at the leaking area.

Water leaks may be detected by visual examination of the domestic hot water coil plate and gasket. Leaks from the boiler tubes or the tube sheet joints will show up as leaks into the end head or front head and will ultimately begin to fill up the final heating chamber with water.

The temperature-pressure gauge on the front of the boiler indicates the boiler water

temperature and pressure. The pressure should not exceed 30 psi for water boilers or 15 psi for steam boilers. The pressure is set by the pressure reducing valve on the water make-up piping on water installations.

The pressure on a steam boiler is set by the Pressuretrol on the front of the boiler. The temperature is set by the Triple Aquastat on water boilers. The temperature on steam units is a function of the pressure and will normally operate while steaming at 212° at 0 psi. At 15 psi the temperature would be about 250° F.

If the boiler water is hot enough and domestic hot water is still not satisfactory, the system could have some oil film which may have insulated the fins on the hot water coil. The coil has to be removed to make this determination. In cases where the domestic hot water has a high hardness level, the hot water coil could be insulated by a build-up of a hard white coating. This is a gradual process and it would not show up as a problem at installation.

This can be corrected by flushing acid through the coil to remove the build-up. (Please consult your service man.)

INSTRUCTIONS FOR DISASSEMBLY AND REASSEMBLY OF BOILER

DISASSEMBLY:

1. Remove four brass nuts on the end head.
2. Drop end head to horizontal position on hinge, being careful not to let scroll drop.
3. Mark scroll and tube sheet with a black marker, remove scroll, take note which side goes against tube sheet.
4. Remove hinge bolt. End head is now free of boiler.
5. Disconnect electrical wiring from burner.
6. Disconnect Fuel Line(s) from burner.
7. Remove four brass nuts from front head assembly. Remove assembly from boiler carefully to avoid damage to gaskets and air tube insulator.
8. Replace rope gasketing on front and end heads after **every** maintenance.

RE-ASSEMBLY:

9. Place front head in position, reassemble in the following steps.
10. Tighten four brass nuts evenly and across corners to further assure a tight seal.
11. Mount burner, reconnect electrical wiring and fuel lines(s).
12. Make sure combustion tube liner is fully seated against air tube insulator.
13. Mount scroll on fire tubes.
14. Replace hinge bolt through end head casting, and carefully close end head. Use care not to disturb scroll. If scroll falls away from tubes when attempting to close end head, wedge a piece of cardboard between a tube and scroll to keep in place.
15. Tighten brass nuts evenly and across corners until gasket is tight.
16. Bleed line to pump. Unit is now ready for firing.
17. Proceed with start-up procedure, record CO₂, smoke readings, and air adjustment for homeowner.

BOILER CLEANING PROCEDURE

1. Remove four brass nuts at end head and drop down to expose tubes and scroll. Inspect scroll for cracks and other damage. Replace, if necessary.
2. Clean small tubes with vacuum cleaner or tube brush. If there is any carbon in combustion tube, clean out.
3. Inspect end head refractory insert. Clean inspection sight glass.
4. Replace end head rope gasket.
5. Remove cleanout cover at burner end and clean thoroughly with vacuum.
6. Remove smoke pipe and clean belly connection, if required. Retape smoke pipe upon reinstalling. Inspect chimney for any deterioration or excess carbon. Clean or repair as necessary.
7. Remove nozzle assembly. Clean and check electrodes. Replace nozzle, making sure to use the proper size and angle.

8. Replace oil filter element.
9. If there is any indication that gaskets are leaking, replace immediately.
10. Reinstall cleanout cover, scroll, end head and stack connections. Make sure all vent connections are taped and secured with screws.

NOTE: The scroll is important to assure efficient operation. DO NOT OMIT SCROLL.

11. Fire boiler, check again for leaks in gaskets, and stack joints. Make sure CO₂, air control setting and smoke test are as they should be. Consult start-up procedure.

DYNATHERM FP SERIES SPECIFICATION SHEET

FP Series

MODEL NO.	FIRING RATE GPH	D.O.E. HEATING CAPACITY MBH	NET IBR RATING WATER		EFFICIENCY STEADY STATE		HEAT TRANSFER SURFACE SQ.FT.	WATER CONTANTS GAL.	DOMESTIC HOT WATER COIL GPM		STACK TEMP OF		CO 2
			MBH	SQ.FT.	COMB.	AFUE			P1	P2	GR	NET	
WS18	0.65	81.7	71	484	89.1	87.5	7.5	8	0	0.0	290	230	
	0.85	105.4	92	611	88.2	86.3	7.5	8	0	0.0	325	265	13%
	1.00	121.7	106	706	86.7	84.8	7.5	8	0	0.0	370	310	
	1.10	132.8	118	808	85.8	83.3	7.5	8	0	0.0	395	340	
18	0.65	81.7	71	484	89.1	87.3	19.0	19	4	1.8	290	230	
	0.85	105.4	92	611	88.2	86.1	19.0	19	4	2.3	325	265	13%
	1.00	121.7	106	706	86.7	84.5	19.0	19	4	2.7	370	310	
24	0.85	106.7	93	620	89.2	87.2	23.5	25	5	2.3	240	180	
	1.00	123.7	108	720	88.1	85.9	23.5	25	5	2.7	275	215	13%
	1.25	152.1	132	880	86.5	83.9	23.5	25	5	3.3	350	290	
36	1.25	159.3	139	927	90.5	88.5	32.5	38	6	3.4	260	200	
	1.35	170.9	149	993	89.9	87.9	32.5	38	6	3.7	285	225	13%
	1.50	187.9	164	1093	89.0	87.0	32.5	38	6	4.1	325	265	
42	1.50	192.0	167	1113	90.9	88.9	37.0	45	6	4.2	250	190	
	1.65	209.1	182	1213	90.0	88.0	37.0	45	6	4.6	290	230	13%
	1.85	231.2	201	1340	88.8	86.8	37.0	45	6	5.0	320	260	

P1 is Coil Capacity at 180 degree "F", Intermittent Draw. Use these ratings to compare with other boilers.
 P2 indicates DYNATHERMS ability to heat 40 degree "F" water to 140 degree, without interruption, at the rated flow.
 *DOE Annual Fuel Use Efficiency.

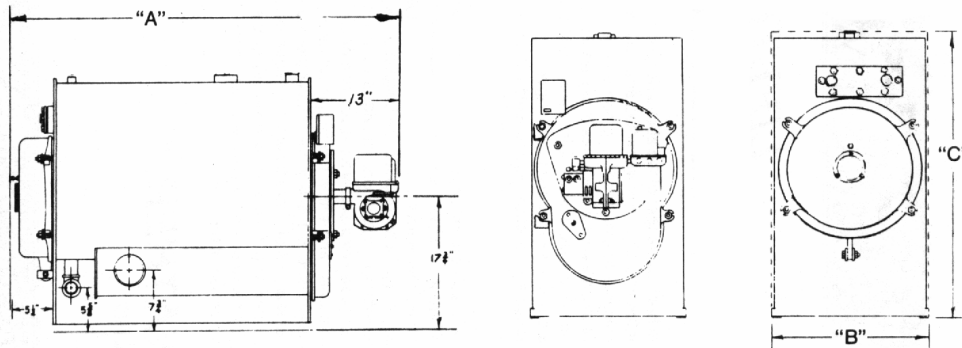

Dimensions:

MODEL NO.	LENGTH	WIDTH	HEIGHT	SHIP # LBS.	INSTALLATION CLEARANCE (MINIMUM)				FLUE & FITTINGS		
					TOP	SIDE	FRONT	REAR	FLUE (DIA)	CHIMNEY (MIN.)	OUTLET RETURN
WS18	36.5"	18.5"	25"	355	6"	12"	24"	20"	5"	6"RD	21/2" NPT
18	36.5"	18.5"	35"	500	6"	12"	24"	20"	5"		
24	42.5"	18.5"	35"	555	6"	12"	24"	26"	5"		
36	54.5"	18.5"	35"	665	6"	12"	24"	38"	5"	6X6 SQ	
42	60.5"	18.5"	35"	720	6"	12"	24"	44"	5"		

DYNATHERM RATINGS AND APPROVALS

DYNATHERM's are rated in accordance with I-B-R recommendations. The **DYNATHERM** ASME boilers have the "H" ASME Constructed stamp, as well as a National Board number.

All burners and electrical components provided by the manufacturer with a **DYNATHERM** boiler are UL approved.

DOE RATED



IBR RATED



ASME CONSTRUCTED (Available)

DIRECT VENT APPLICATIONS

Direct Vent applications are in accordance with the NFPA 31 Standard for the Installation of Oil-Burning Equipment as listed on page 31-13, Section 1-12.2 Direct Vent Applications as referred to by BOCO. Side wall venting and in-ground venting applications are approved by **DYNATHERM** when installed according to their Installation Instructions.

NOTES: